

Material Specification

HEADRAIL BRACED - POWDER COATED METAL TOILET PARTITIONS - ELITE

1.01 Construction Features

Doors, Panels and Pilasters shall be constructed of two sheets of panel flatness zinc - coated galvalume steel, ASTM A653 GR33, laminated under pressure to a honeycomb core for sound deadening and rigidity. Formed edges to be welded together and inter-locked under tension with a roll - formed oval crown locking bar, mitred, welded and ground smooth at the corners. Honeycomb to have a maximum 25 mm (1") cell size.

1.02 Doors

Shall be 1613mm (63.5") high and 25mm (1") thick with cover sheets not less than 0.8mm (.030").

1.03 Panels

Shall be 1613mm (63.5") high and (1") thick with cover sheets not less than 0.8mm (.030").

1.04 Pilasters

Shall be 32mm (1.25") thick with cover sheets not less than 0.8mm (.030").

1.05 Headrail

Shall be 25mm (1") by 41mm (1.625") extruded anodized aluminum with anti-grip design. Wall thickness to be 1.5mm (.060") and shall be securely attached to wall and pilasters with manufacturer's fittings in such a way as to make a strong and rigid installation. All joints in headrails shall be made at a pilaster.

1.06 Pilaster Fastening Method

Pilasters shall be securely and rigidly fastened to the floor and fitted with a jack levelling screw for vertical adjustment. The floor fastening shall be concealed and protected by a 102mm (4") high, die-formed stainless steel pilaster shoe.

1.07 Hardware and Fittings

Panel-to-pilaster, panel-to-wall, and pilaster-to-wall connections are made with full-height channels, finished to match partitions. Fasteners are zinc plated 12 x 1-3/4" and 12 x 5/8" TR-27 6-lobe security screws.

Doors shall be equipped with chrome plated zinc die cast gravity type hinges, mounted on upper and lower pilaster hinge brackets. Threaded top hinge pin shall be metal with a self-lubricating nylon sleeve. Door hinges shall be wrap-around style and adjustable to permit the door to come to rest at any position when not latched.

Coat Hook and Bumper: Each door to be fitted with a combined coat hook and bumper. Finish to match other hardware items.

Latch to be a concealed, chrome plated zinc die casting with face mortised flush with edge strip of door.

A full length aluminum continuous stop and full length aluminum hinge side filler eliminate all sightline gaps between pilasters and doors.

Pilaster shoes to be stainless steel with a #4 brushed finish.

1.08 Finish

All sheet metal to be thoroughly cleaned, phosphated and finished with a high performance powder coating, baked on to provide a uniform smooth protective finish. Color shall be as selected from Hadrian's color card.

Metal Toilet Partitions
Elite Series - Headrail Braced - 9" [229mm] AFF
Chrome - Concealed Latch & Wrap Hinge
Channels - Continuous Stops & Hinge Fillers

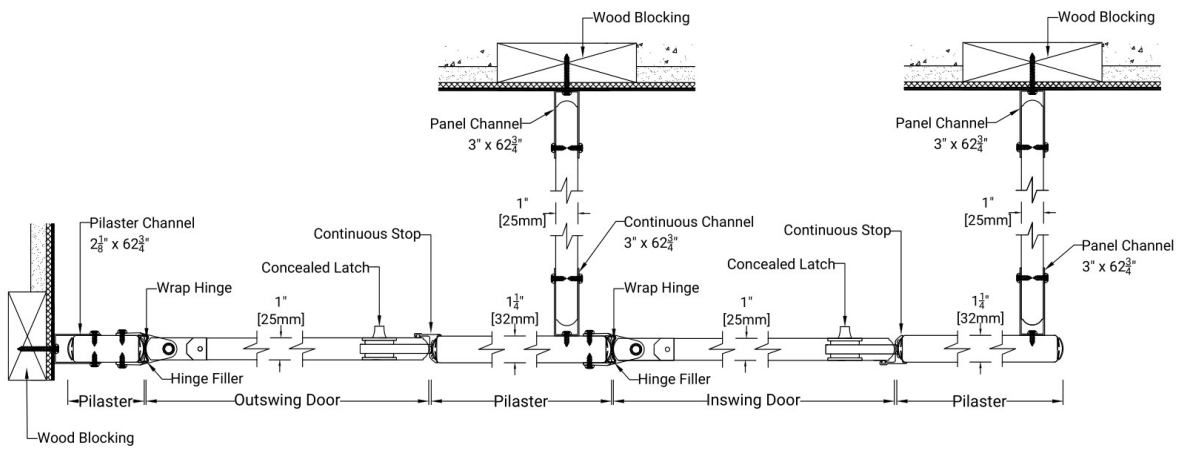
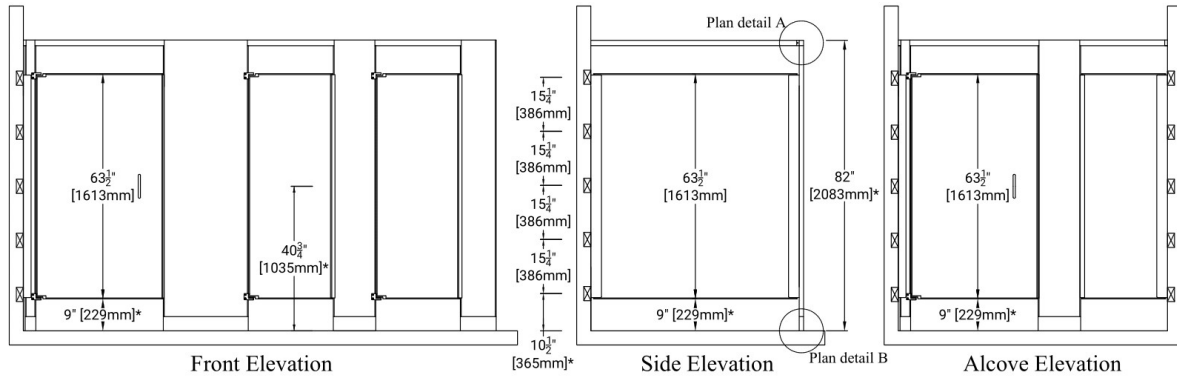

1" [25mm] x 1 1/8" [41mm] extruded anodized aluminum anti-grip headrail. Headrail sits 3/8" [3mm] above pilaster.

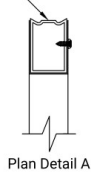

Plan Detail A

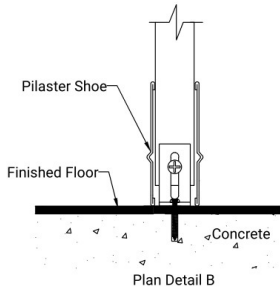

Plan Detail B

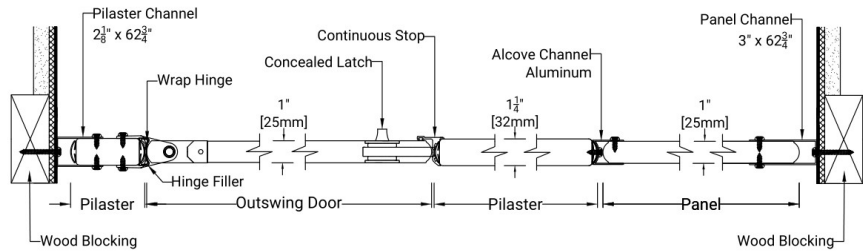

Important Notes:

Refer to final drawings for wood blocking information. Wood blocking is critical to ensure a rigid installation. See material specifications for material and hardware finishes.

*Above finish floor dimensions may vary due to floor level and cam position

Metal Toilet Partitions
Elite Series - Headrail Braced - 6" [152mm] AFF
Chrome - Concealed Latch & Wrap Hinge
Channels - Continuous Stops & Hinge Fillers

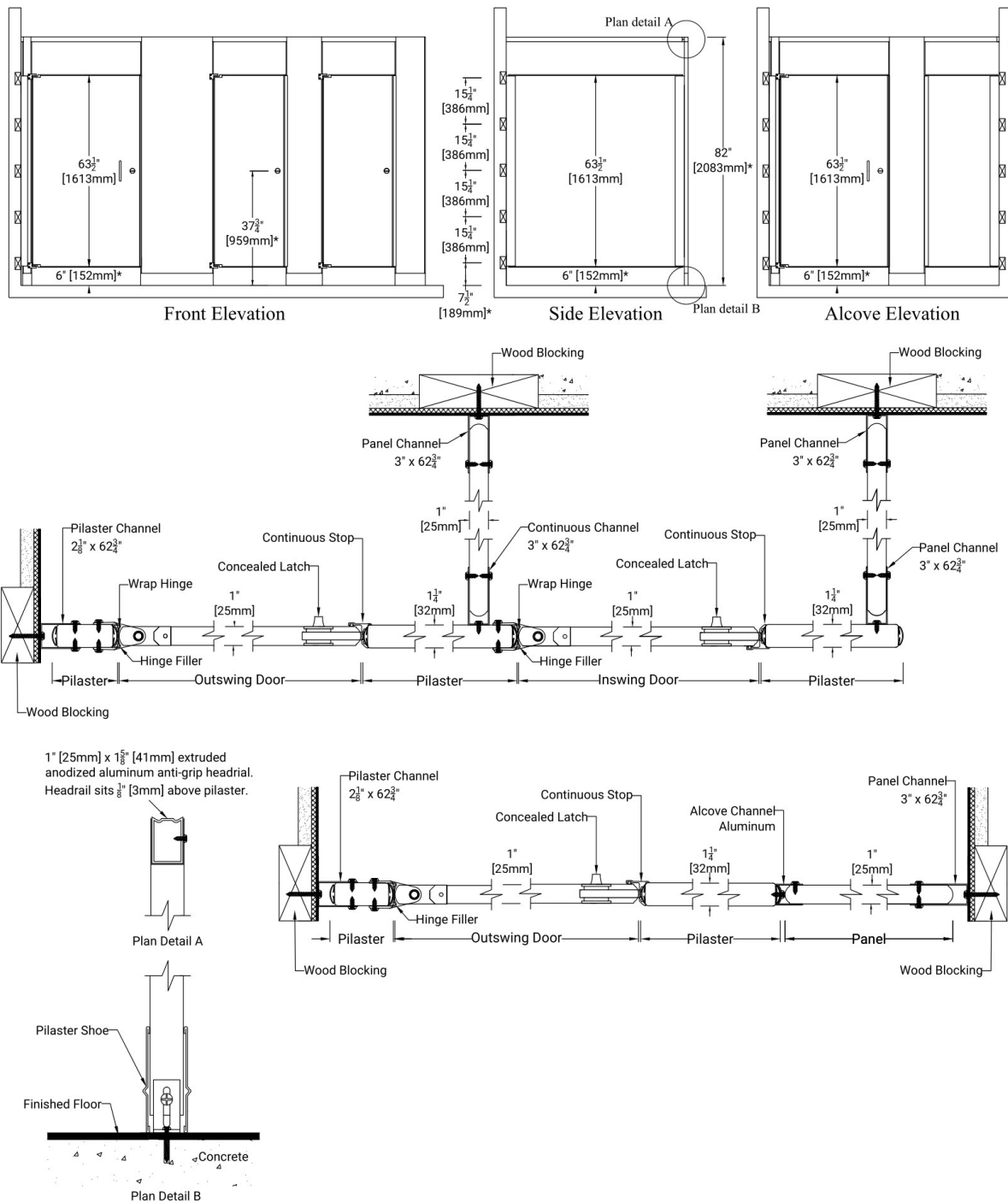

Important Notes:

Refer to final drawings for wood blocking information. Wood blocking is critical to ensure a rigid installation. See material specifications for material and hardware finishes.

*Above finish floor dimensions may vary due to floor level and cam position