

Tools Required

- 4 ft. level
- Hammer
- Hammer drill
- Misc. screwdriver bits
- Hacksaw
- Misc. drill bits, including 4mm (5/32") & 8mm (5/16")
- 6mm (1/4") masonry bit
- 11mm (7/16") wrench
- 13mm (1/2") wrench
- Chalkline
- 318mm (12.5") shim block
- 6-lobe driver bit for upper hinge pin
- Tape measure

M E T A L

HEADRAIL BRACED INSTALLATION MANUAL



General Notes

The following installation instructions are based on the most common unit arrangement. Other arrangements will be encountered, i.e. units contained between two walls or between two freestanding panels.

For dimensional information, refer to your plan layout and dimensional details. Note in particular the relationship of the panels to the pilasters (panels do not necessarily fall on the centerline of the pilaster).

Varying site conditions can affect the installation process. To effect a rigid and level installation, it is important for installers to be aware of and compensate for uneven floor and wall conditions.

It is the distributor's responsibility to supply end-users with maintenance and warranty information.

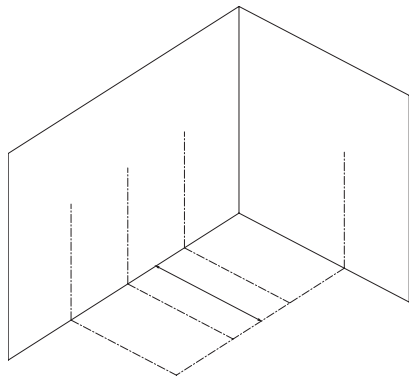

1

Establish Floor Bracket Locations

Establish front centerline by taking the overall compartment dimension and deducting 16 mm (5/8").

Use final layout drawings to determine locations.

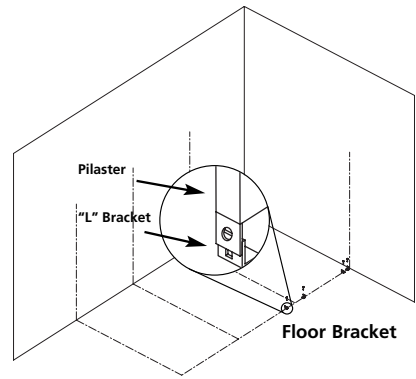

2

Fasten Floor Brackets

Drill holes for floor brackets 22mm (7/8") in from edge of pilaster locations as indicated on layout drawing.

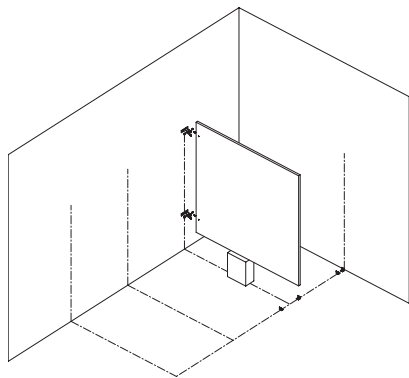

3

Erect Panel

Using your centerline locations, fasten 2 panel brackets to wall. Bracket centers should be 457mm (18") and 1626mm (64") from floor.

Rest panel on 318mm (12.5") block and position in brackets, leaving 13mm (1/2") clearance between wall and panel. Drill one hole through top bracket and fasten.

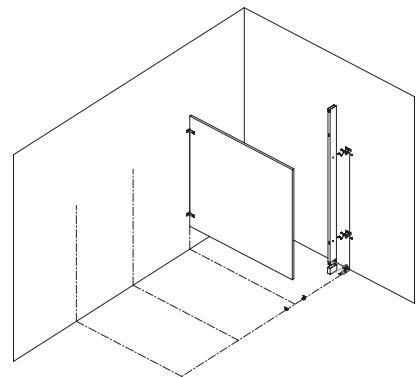

4

Erect Wall Pilaster

Fasten 2 "F" brackets to wall at centerline. Bracket centers should be 457mm (18") and 1626mm (64") from floor.

Slide shoe onto pilaster. Position pilaster in wall brackets and over floor brackets. Install floor bracket hardware and leveling device, plumb pilaster, and tighten. Attach pilaster to wall brackets.

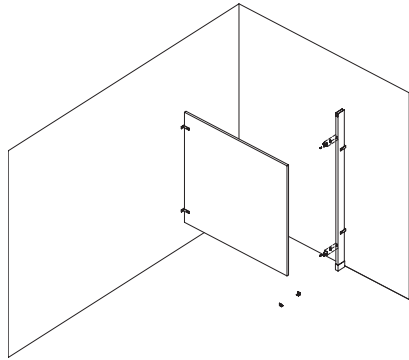

5

Prepare Pilaster For Door

Fasten upper and lower hinges to wall pilaster.

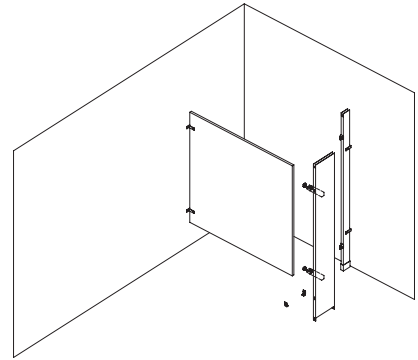

6

Fasten "U" Brackets To Pilaster

Place next pilaster on floor brackets and mark center line of panel on the back. Mark bracket centers at 457mm (18") and 1626mm (64") from floor. Using the brackets as templates, mark drill holes.

Remove pilaster from floor brackets and fasten "U" brackets.

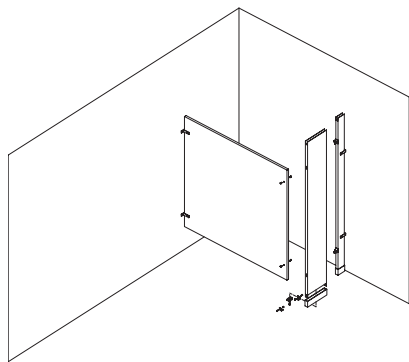

7

Erect Pilaster

Slide shoe onto pilaster. Insert leveling device and position pilaster on floor brackets (do NOT tighten yet) with "U" brackets engaging panel.

Drill one hole through top bracket and fasten.

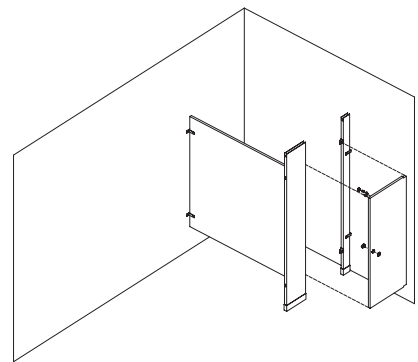

8

Prepare Door For Hanging

Install female cam in the door.

Install latch, and coat hook/bumper.

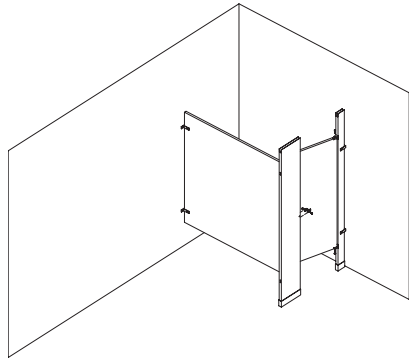

9

Hang Door

Insert male cam into bottom hinge and lower door onto it. Install threaded upper hinge pin. To set doors at the required angle, loosen the nut of the male cam assembly, set door at required angle, and tighten nut.

Fasten Stop & Keeper on pilaster, ensuring it lines up with latch.

At this stage, you may want to pre-install headrail (without fastening) to assist in lining up/spacing pilasters.

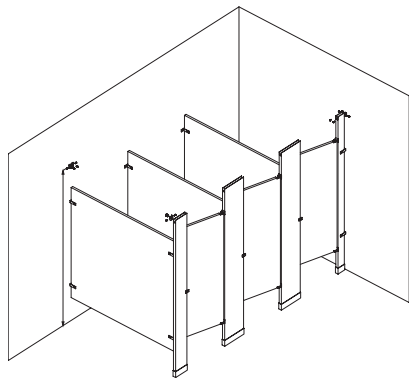

11

Secure Headrail Brackets

Fasten headrail brackets to wall approximately 2070mm (81.5") above the floor (some adjustment may be necessary due to varying floor conditions).

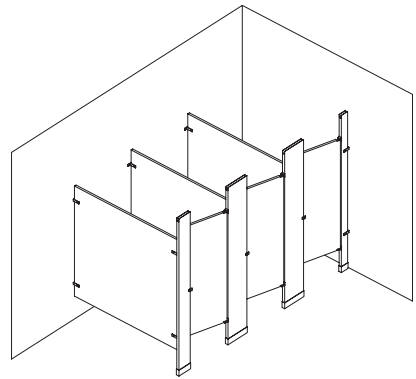

10

Erect Remaining Compartments

Ensure all pilasters are fastened to floor brackets, add all remaining fasteners and repeat steps 3-10 (as necessary) for all remaining compartments.

Note: Hadrian recommends installing one compartment (including door) at a time.

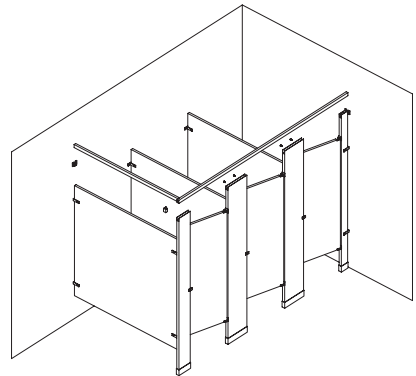

12

Place Headrail

Place headrail into tops of pilasters and slide into headrail brackets.

Fasten headrail to pilasters (screws on inside of compartment) and to headrail wall brackets. Install headrail end cap if required.

Adjust leveling devices to level all compartment components and tighten. Drill all remaining panel holes and fasten to brackets.

Optional Items

Continuous Hinge

Replaces conventional hinge and hinge filler.

Continuous Stop

Replaces doorstep/keeper and offers increased privacy.

Hinge Side Gap Filler

Fits between standard hinges and offers increased privacy.

Hadrian recommends pre-drilling pilasters with 4mm (5/32") holes when installing continuous stops and hinge side gap fillers.

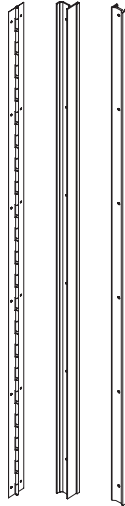

Contact Hadrian:

**IN CANADA &
AREAS OTHER THAN USA:**
Hadrian Manufacturing Inc.,
965 Syscon Road,
Burlington, ON L7L 5S3
tel: 905-333-0300
fax: 905-333-1841
CAN toll free fax: 1-888-817-7701

IN THE USA:
Hadrian Inc.,
7420 Clover Ave.,
Mentor, OH 44060
tel: 440-942-9118
fax: 440-942-9618
USA toll free fax: 1-800-536-1469