

WALL MOUNTED, FLOOR MOUNTED, FLANGE MOUNTED Stainless Steel Urinal Screens

Material Specification

1 . 0 1 Construction

Urinal screen panels shall be constructed of two sheets of panel flatness type 304, #4 brushed finish stainless steel, laminated under pressure to a "verticel" (1/2") honeycomb core for impact resistance, rigidity and sound deadening. Formed edges to be welded together and inter-locked under tension with a roll-formed oval crown stainless steel locking bar, mitred, welded and ground smooth at the corners. Honeycomb to be of virgin, long fibre paper with a maximum 12.5mm (1/2") cell size.

1 . 0 2 Wall Mounted Screens

Panels shall be 25mm (1") thick with corner sheets not less than 22 gauge (0.8mm or .030"). The two cover sheets shall have edges sealed with a continuous oval-crown locking strip. Corners shall be welded and ground smooth. Screen must be 18" or 24" deep, and 42" high and anchored into wall approximately 12" off the floor with two brackets spaced 29-1/2" apart.

1 . 0 3 Floor Mounted Screens

Panels shall be 25mm (1") thick with cover sheets not less than 22 gauge (0.8mm or .030"). Supporting pilasters shall be 127mm (5") wide, 32mm (1.25") thick with cover sheets not less than 18 gauge (1.2mm or .048"). The two cover sheets shall have edges sealed with a continuous oval-crown locking strip. Corners shall be welded and ground smooth. Pilasters shall be securely and rigidly fastened to the floor using 19mm (.75") diameter expansion shield with spacer and nuts for leveling of pilasters. Floors, preferably concrete, should not be less than 127mm (5") thick for rigidity and anchorage. The floor fastening shall be concealed and protected by a 102mm (4") high, die-formed stainless steel pilaster shoe. Screen must be 58" high in varied depths and anchored approximately 12" off the floor with two brackets spaced 45-1/2" apart.

1 . 0 4 Flange Mounted Screen

Panels shall be 25mm (1") thick with corner sheets not less than 22 gauge (0.8mm or .030"). The two cover sheets shall have edges sealed with a continuous oval-crown locking strip. Corners shall be welded and ground smooth. Screen must be 18" or 24" deep, and 42" high. It shall be constructed of a one-piece 12 gauge full-length galvanized mounting backplate 4" wide and two pieces of full length angle brace 1-1/2" x 3" inserted and attached into the screen. It shall be attached to a concrete wall using 6 each 1/4" concrete rawl anchors to provide rigidity. (Not recommended for hollow wall installations).

1 . 0 5 Hardware & Fittings

Wall Mounted and Floor Mounted brackets shall be chrome plated zinc die castings. Fasteners are 12 x 1-1/2" and 12 x 5/8" quad screws.

1 . 0 6 Finish

Type 304, #4 brushed finish.

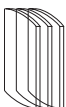

WALL MOUNTED, FLOOR MOUNTED, FLANGE MOUNTED Stainless Steel Urinal Screens

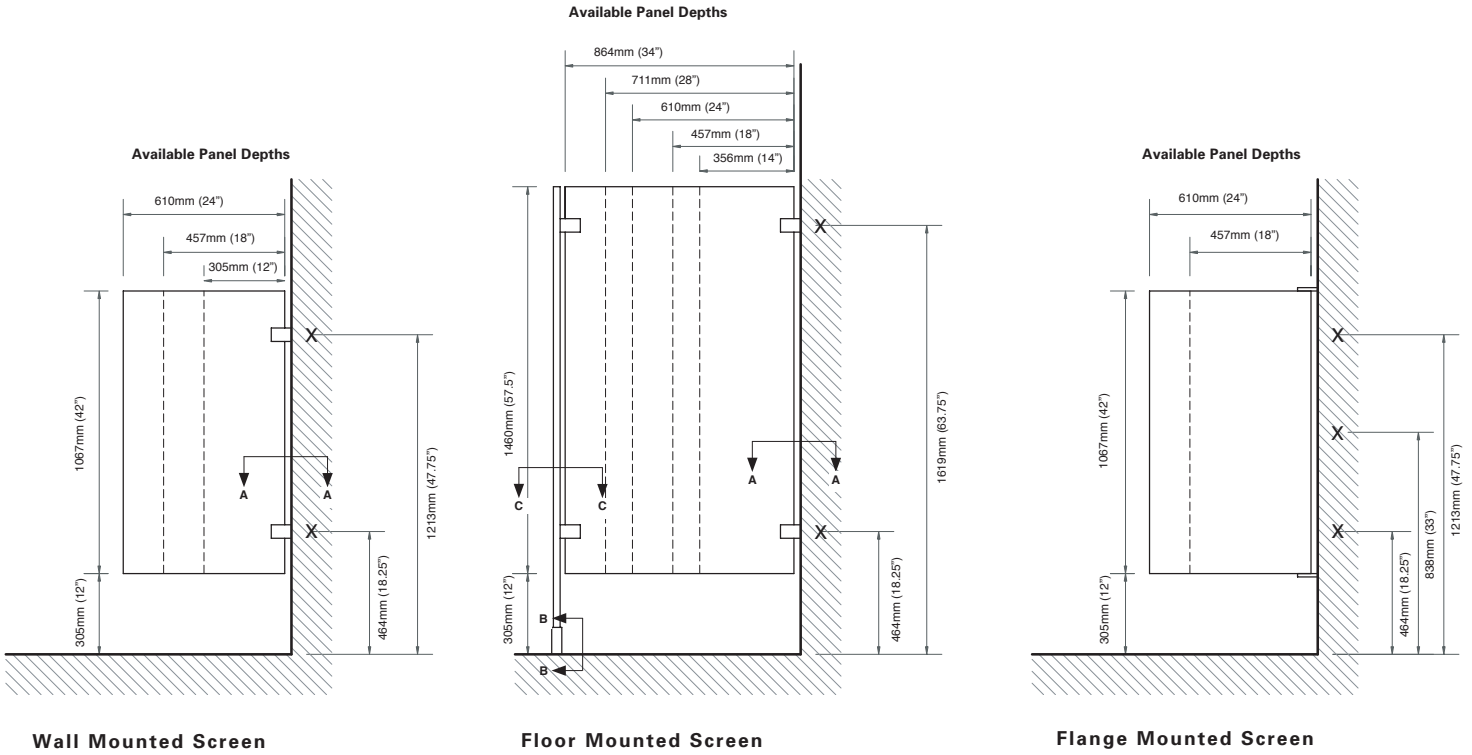

Wall Mounted Screen

Floor Mounted Screen

Flange Mounted Screen

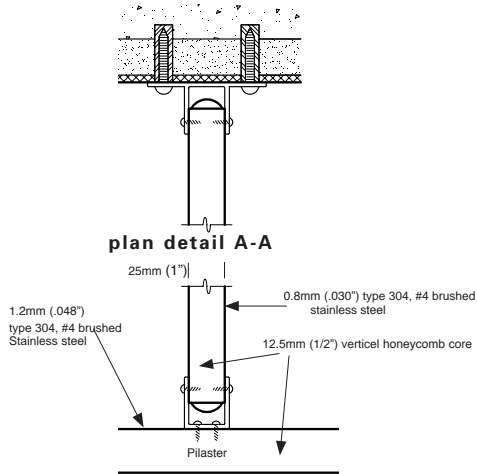

plan detail C-C

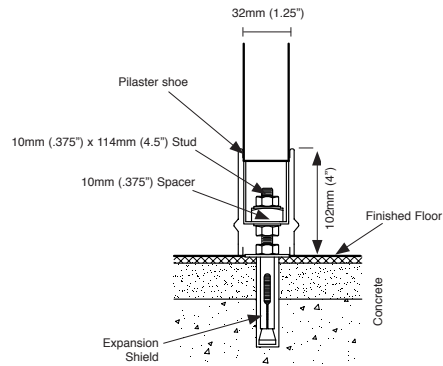

section detail B-B

Important Note:
Wood blocking to be provided at all locations marked X

Custom sizes available

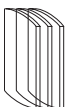

Hadrian Manufacturing Inc., 965 Syscon Road, Burlington, ON, Canada, L7L 5S3 • Tel: (905) 333-0300 • Fax: (905) 333-1841
Hadrian Inc., 7420 Clover Avenue, Mentor, OH, U.S.A., 44060 • Tel: (440) 942-9118 • Fax: (440) 942-9618
www.hadrian-inc.com