

WALL MOUNTED, FLOOR MOUNTED, FLANGE MOUNTED Metal Urinal Screens

Material Specification

1 . 0 1 Construction

Urinal screen panels shall be constructed of two sheets of panel flatness zinc-coated galvalume steel, ASTM A653 GR33, laminated under pressure to a honeycomb core for sound deadening and rigidity. Formed edges to be welded together and inter-locked under tension with a roll-formed oval crown locking bar, mitred, welded and ground smooth at the corners. Honeycomb to have a maximum 25mm (1") cell size.

1 . 0 2 Wall Mounted Screens

Panels shall be 25mm (1") thick with corner sheets not less than 22 gauge (0.8mm or .030"). The two cover sheets shall have edges sealed with a continuous oval-crown locking strip, mitred, welded and finished with a high-performance polymer powder coating. Corners shall be welded, ground smooth, and powder coated with finish to match locking strip. Screen must be 18" or 24" deep, and 42" high and anchored into wall approximately 12" off the floor with two brackets spaced 29-1/2" apart.

1 . 0 3 Floor Mounted Screens

Panels shall be 25mm (1") thick with cover sheets not less than 22 gauge (0.8mm or .030"). Supporting pilasters shall be 127mm (5") wide, 32mm (1.25") thick with cover sheets not less than 18 gauge (1.2mm or .048"). The two cover sheets shall have edges sealed with a continuous oval-crown locking strip, mitred, welded and finished with a high performance polymer powder coating. Corners shall be welded, ground smooth, and powder coated with finish to match locking strip. Pilasters shall be securely and rigidly fastened to the floor using 19mm (.75") diameter expansion shield with spacer and nuts for leveling of pilasters. Floors, preferably concrete, should not be less than 127mm (5") thick for rigidity and anchorage. The floor fastening shall be concealed and protected by a 102mm(4") high, die-formed stainless steel pilaster shoe. Screen must be 58" high in varied depths and anchored approximately 12" off the floor with two brackets spaced 45-1/2" apart.

1 . 0 4 Flange Mounted Screen

Panels shall be 25mm (1") thick with corner sheets not less than 22 gauge (0.8mm or .030"). The two cover sheets shall have edges sealed with a continuous oval-crown locking strip, mitred, welded and finished with a high performance polymer powder coating. Corners shall be welded, ground smooth, and powder coated with finish to match locking strip. Screen must be 18" or 24" deep, and 42" high. It shall be constructed of a one-piece 12 gauge full-length galvanized mounting backplate 4" wide and two pieces of full length angle brace 1-1/2" x 3" inserted and attached into the screen. It shall be attached to a concrete wall using 6 each 1/4" concrete rawl anchors to provide rigidity. (Not recommended for hollow wall installations).

1 . 0 5 Hardware & Fittings

Wall Mounted and Floor Mounted brackets shall be chrome plated zinc die castings. Fasteners are 12 x 1-1/2" and 12 x 5/8" quad screws.

1 . 0 6 Finish

All sheet metal to be thoroughly cleaned, phosphated and finished with a high performance powder coating, baked on to provide a uniform smooth protective finish. Color shall be as selected from Hadrian's Color Chart.

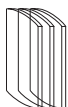

WALL MOUNTED, FLOOR MOUNTED, FLANGE MOUNTED Metal Urinal Screens

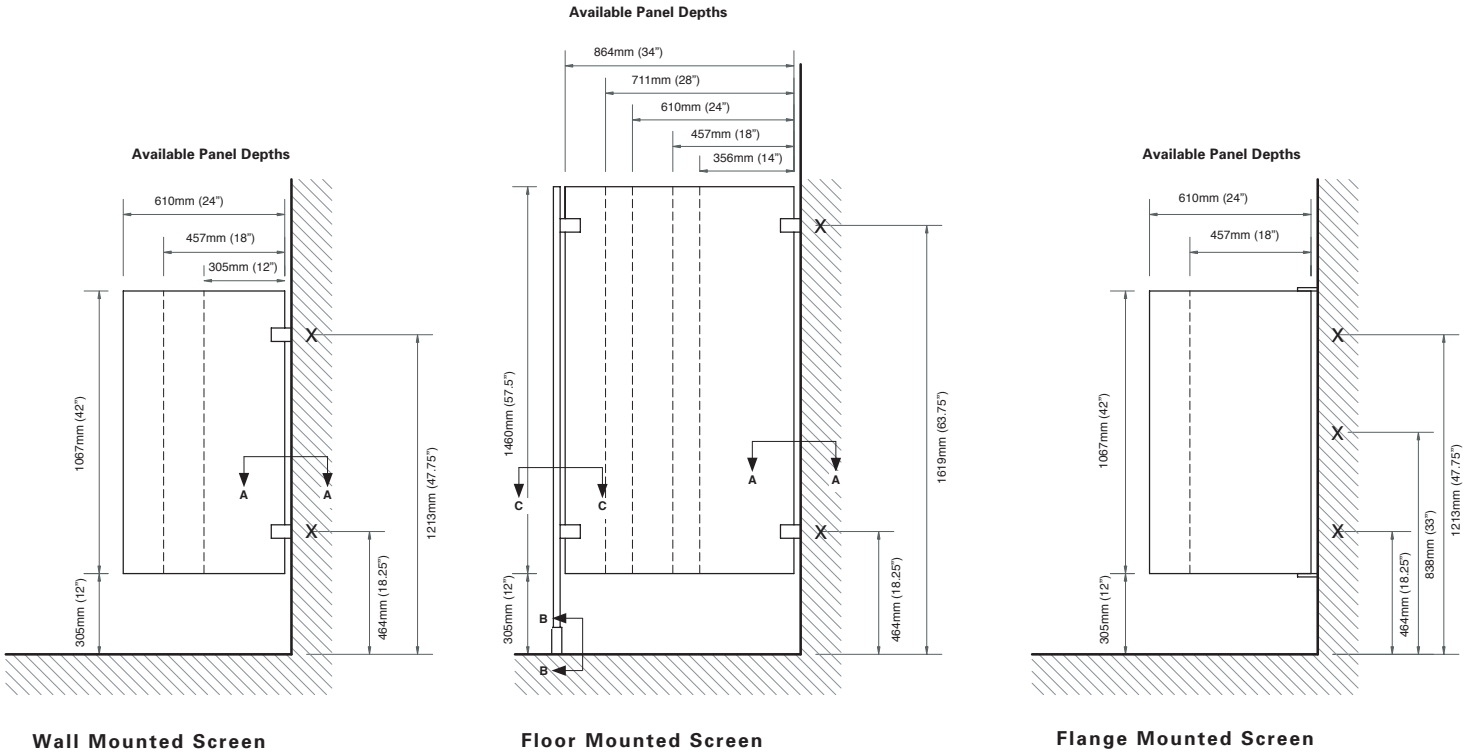

Wall Mounted Screen

Floor Mounted Screen

Flange Mounted Screen

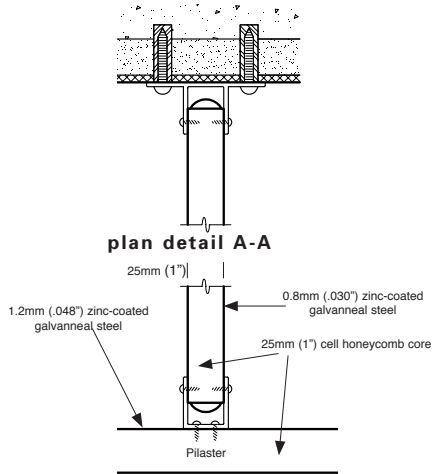

plan detail C-C

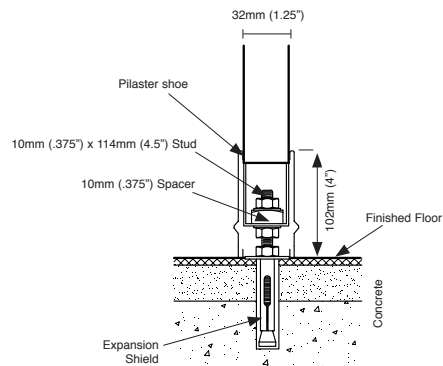

section detail B-B

Important Note:
Wood blocking to be provided at all locations marked X

Custom sizes available

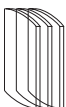

Hadrian Manufacturing Inc., 965 Syscon Road, Burlington, ON, Canada, L7L 5S3 • Tel: (905) 333-0300 • Fax: (905) 333-1841
Hadrian Inc., 7420 Clover Avenue, Mentor, OH, U.S.A., 44060 • Tel: (440) 942-9118 • Fax: (440) 942-9618
www.hadrian-inc.com