

## Embossed Stainless Steel - Floor to Ceiling ELITE PLUS SERIES Metal Toilet Partitions

### Material Specification

#### 1 . 0 1 Construction

---

Doors, Panels and Pilasters shall be constructed of two sheets of type 304, Embossed stainless steel with 5WL® pattern, laminated under pressure to a "Verticel" (1/2") honeycomb core for impact resistance, rigidity and sound deadening. Formed edges to be welded together and interlocked, under tension, with a roll-formed oval crown stainless steel locking bar, mitred, welded and ground smooth at the corners. Honeycomb to be of virgin, long fiber paper with a maximum 12.5mm (1/2") cell size.

#### 1 . 0 2 Doors

---

Shall be 25mm (1") thick with cover sheets not less than 0.8mm (.030").

#### 1 . 0 3 Panels

---

Shall be 25mm (1") thick with cover sheets not less than 0.8mm (.030").

#### 1 . 0 4 Pilasters

---

Shall be 32mm (1.25") thick with cover sheets not less than 1.2mm (.048").

#### 1 . 0 5 Pilaster Fastening Method

---

AT FLOOR: Pilasters shall be securely and rigidly fastened to the floor and fitted with a jack levelling screw for vertical adjustment. The floor fastening shall be concealed and protected by a 102mm (4") high, die-formed stainless steel pilaster shoe.

AT CEILING: Pilasters shall be rigidly fastened to structural steel or pre-cast concrete supporting member (Note: wood support is not acceptable) by means of two heavy hanging studs permitting vertical adjustment between bottom of supporting member and finished ceiling line. Pilaster ceiling studs supplied by manufacturer. The top connection shall be concealed by a 102mm (4") high, die-formed stainless steel pilaster shoe. NOTE: The specification does not include the supplying, installing, drilling or tapping of any of the structural members required in the ceiling for the support of these units. Only the studs are supplied for installation by others.

#### 1 . 0 6 Hardware & Fittings

---

All panel and pilaster brackets and all door hardware shall be chrome plated zinc die castings. Fasteners are 12 x 1-3/4" and 12 x 5/8" TR-27 6-lobe security screws. Doors shall be equipped with gravity type hinges mounted on upper and lower pilaster hinge brackets. Door hinges shall be wrap-around style and adjustable to permit the door to come to rest at any position when not latched. Threaded upper hinge pin shall have a metal core and self lubricating nylon sleeve to ensure smooth, quiet operation. Each door to be fitted with a combined coat hook and bumper and a concealed latch, with face mortised flush with edge strip of door. A full length continuous stop and hinge side filler eliminate all sightline gaps between pilasters and doors.

#### 1 . 0 7 Finish

---

Type 304, Embossed stainless steel with 5WL® pattern.

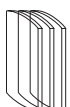

## Embossed Stainless Steel - Floor to Ceiling ELITE PLUS SERIES Metal Toilet Partitions

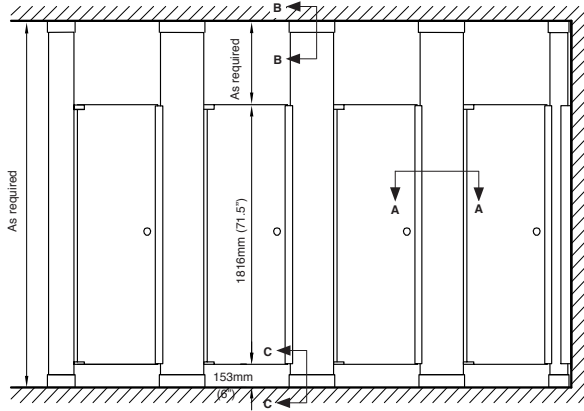

front elevation

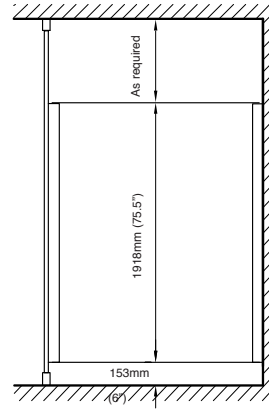

side elevation

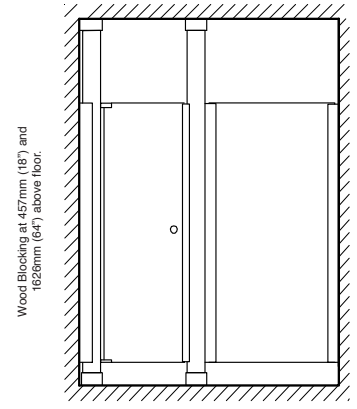

alcove elevation

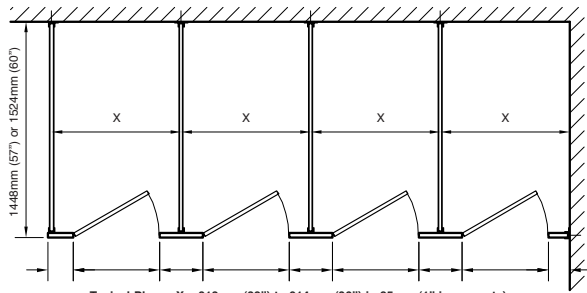

plan

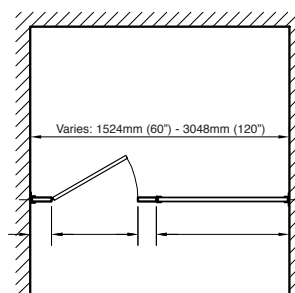

alcove plan

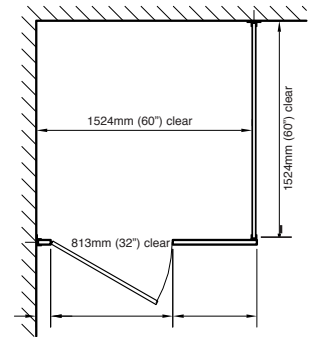

barrier-free plan

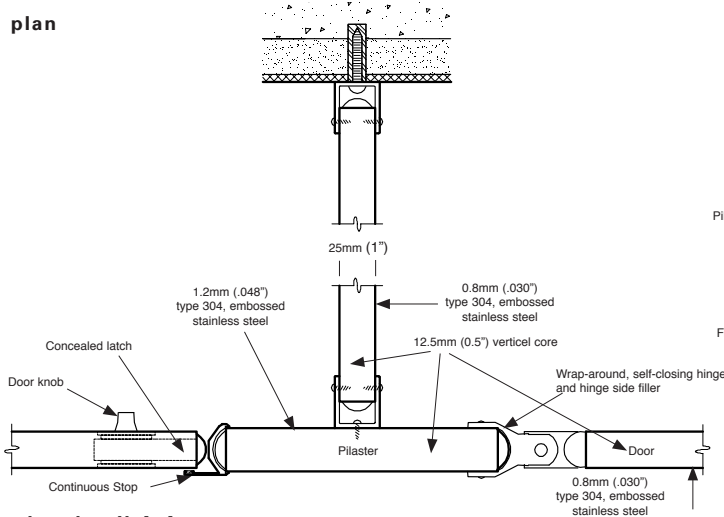

plan detail A-A

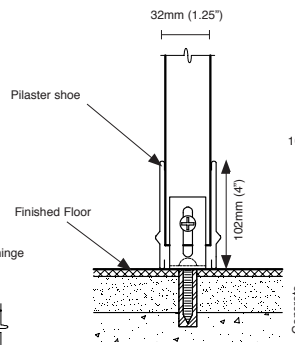

section details C-C

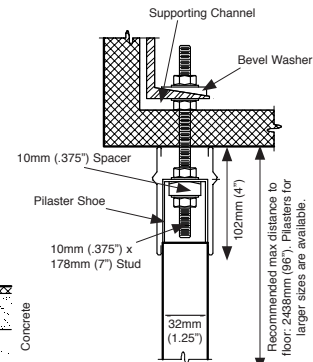

section B-B

### Important Notes:

Refer to final drawings for wood blocking information. Wood blocking is critical to ensure a rigid installation. Structural steel or pre-cast concrete required as ceiling support. Wood support is not acceptable. Structural ceiling support and drilling for studs by others. Studs supplied by Hadrian but installed by others.

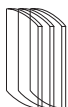

**Hadrian Manufacturing Inc.,** 965 Syscon Road, Burlington, ON, Canada, L7L 5S3 • Tel: (905) 333-0300 • Fax: (905) 333-1841  
**Hadrian Inc.,** 7420 Clover Avenue, Mentor, OH, U.S.A., 44060 • Tel: (440) 942-9118 • Fax: (440) 942-9618  
[www.hadrian-inc.com](http://www.hadrian-inc.com)