

## Powder Coated - Ceiling Hung STANDARD Metal Toilet Partitions

### Material Specification

#### 1 . 0 1      **Construction**

---

Doors, Panels and Pilasters shall be constructed of two sheets of panel flatness zinc-coated galvanized steel, ASTM A653 GR33, laminated under pressure to a honeycomb core for sound deadening and rigidity. Formed edges to be welded together and inter-locked under tension with a roll-formed oval crown locking bar, mitred, welded and ground smooth at the corners. Honeycomb to have a maximum 25mm (1") cell size.

#### 1 . 0 2      **Doors**

---

Shall be 25mm (1") thick with cover sheets not less than 0.8mm (.030").

#### 1 . 0 3      **Panels**

---

Shall be 25mm (1") thick with cover sheets not less than 0.8mm (.030").

#### 1 . 0 4      **Pilasters**

---

Shall be 32mm (1.25") thick with cover sheets not less than 1.2mm (.048").

#### 1 . 0 5      **Pilaster Fastening Method**

---

Pilasters shall be rigidly fastened to structural steel or pre-cast concrete supporting member (Note: wood support is not acceptable) by means of two heavy hanging studs permitting vertical adjustment between bottom of supporting member and finished ceiling line. Pilaster ceiling studs supplied by manufacturer. The bottoms of all pilasters shall be truly aligned, and the top connection shall be concealed by a 102mm (4") high, die-formed stainless steel pilaster shoe.

NOTE: The above specification does not include the supplying, installing, drilling or tapping of any of the structural members required in the ceiling for the support of these units. Only the studs are supplied for installation by others.

#### 1 . 0 6      **Hardware & Fittings**

---

All panel and pilaster brackets and all door hardware shall be chrome plated zinc die castings. Fasteners are zinc plated 12 x 1-3/4" and 12 x 5/8" TR-27 6-lobe security screws. Doors shall be equipped with gravity type hinges mounted on upper and lower pilaster hinge brackets. Door hinges shall be fully concealed within the thickness of the door and adjustable to permit the door to come to rest at any position when not latched. Threaded upper hinge pin shall have a metal core and self lubricating nylon sleeve to ensure smooth, quiet operation. Each door to be fitted with a combined coat hook and bumper and a concealed latch, with face mortised flush with edge strip of door. The combined stop and keeper shall have a 19mm (0.75") diameter bumper locked in place.

#### 1 . 0 7      **Finish**

---

All sheet metal to be thoroughly cleaned, phosphated and finished with a high performance powder coating, baked on to provide a uniform, smooth protective finish. Color shall be as selected from Hadrian's color card.

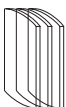

## Powder Coated - Ceiling Hung STANDARD Metal Toilet Partitions

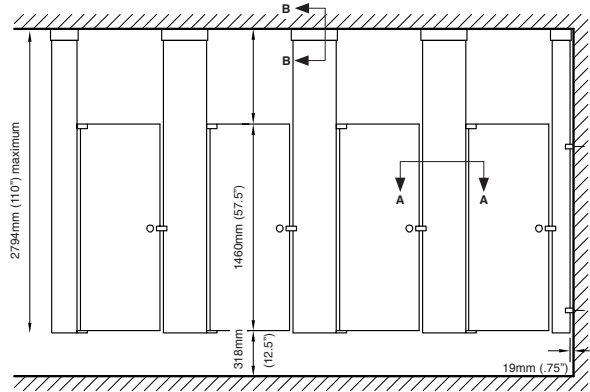

front elevation

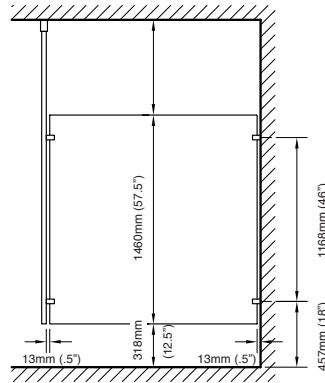

side elevation

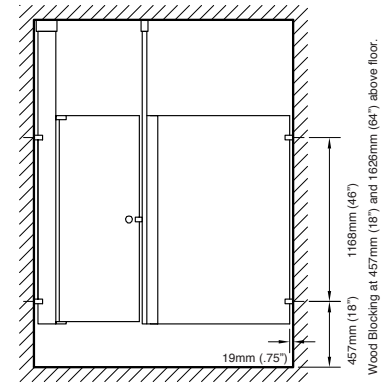

alcove elevation

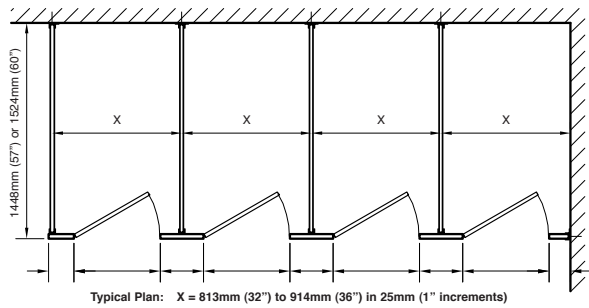

plan

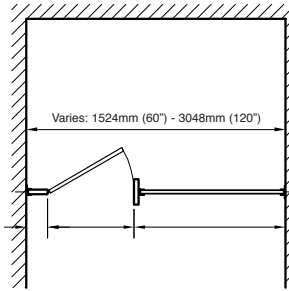

alcove plan

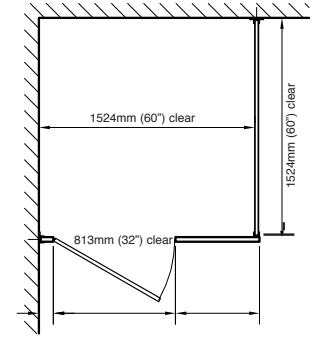

barrier-free plan

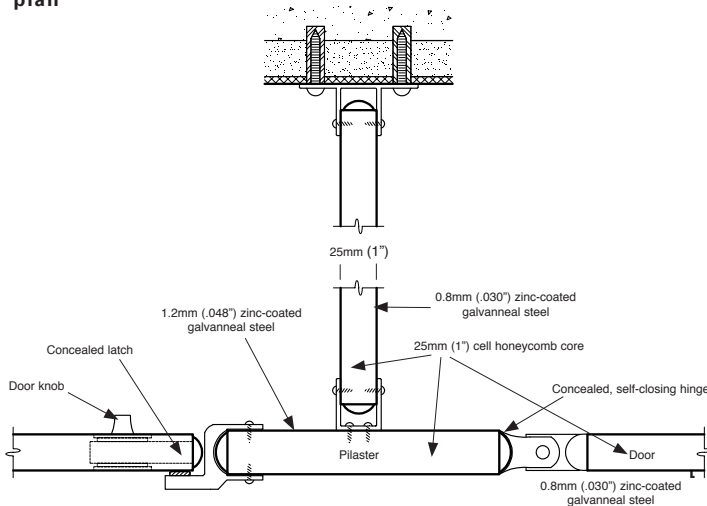

plan detail A-A

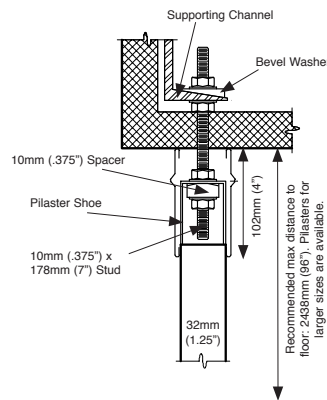

section detail B-B

### Important Notes:

Refer to final drawings for wood blocking information. Wood blocking is critical to ensure a rigid installation. Structural steel or pre-cast concrete required as support (Wood support is not acceptable). Structural support and drilling for studs by others. Studs supplied by Hadrian but installed by others.

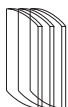

Hadrian Manufacturing Inc., 965 Syscon Road, Burlington, ON, Canada, L7L 5S3

Hadrian Inc.,

www.hadrian-inc.com

7420 Clover Avenue, Mentor, OH, U.S.A., 44060

Tel: (905) 333-0300

Tel: (440) 942-9118

Fax: (905) 333-1841

Fax: (440) 942-9618