

**Powder Coated - Floor Mounted
ELITE SERIES
Metal Toilet Partitions**

Material Specification

1 . 0 1 Construction

Doors, Panels and Pilasters shall be constructed of two sheets of panel flatness zinc-coated galvanneal steel, ASTM A653 GR33, laminated under pressure to a honeycomb core for sound deadening and rigidity. Formed edges to be welded together and inter-locked under tension with a roll-formed oval crown locking bar, mitred, welded and ground smooth at the corners. Honeycomb to have a maximum 25mm (1") cell size.

1 . 0 2 Doors

Shall be 1613mm (63.5") high and 25mm (1") thick with cover sheets not less than 0.8mm (.030").

1 . 0 3 Panels

Shall be 1613mm (63.5") high and 25mm (1") thick with cover sheets not less than 0.8mm (.030").

1 . 0 4 Pilasters

Shall be 32mm (1.25") thick with cover sheets not less than 1.2mm (.048").

1 . 0 5 Pilaster Fastening Method

Pilasters shall be securely and rigidly fastened to the floor using 19mm (.75") diameter expansion shields with spacer and nuts for levelling of pilaster. Floors, preferably concrete, should not be less than 127mm (5") thick for rigidity and anchorage. The floor fastening shall be concealed and protected by a 102mm (4") high, die-formed stainless steel pilaster shoe.

1 . 0 6 Hardware & Fittings

All panel and pilaster brackets and all door hardware shall be chrome plated zinc die castings. Fasteners are zinc plated 12 x 1-3/4" and 12 x 5/8" TR-27 6-lobe security screws. Doors shall be equipped with gravity type hinges mounted on upper and lower pilaster hinge brackets. Door hinges shall be wrap-around style and adjustable to permit the door to come to rest at any position when not latched. Threaded upper hinge pin shall have a metal core and self lubricating nylon sleeve to ensure smooth, quiet operation. Each door to be fitted with a combined coat hook and bumper and a concealed latch, with face mortised flush with edge strip of door. A full length continuous stop and hinge side filler eliminate all sightline gaps between pilasters and doors.

1 . 0 7 Finish

All sheet metal to be thoroughly cleaned, phosphated and finished with a high performance powder coating, baked on to provide a uniform smooth protective finish. Color shall be as selected from Hadrian's color card.

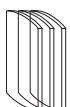

Powder Coated - Floor Mounted ELITE SERIES Metal Toilet Partitions

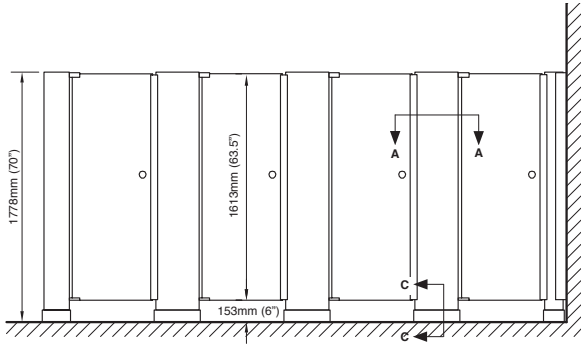

front elevation

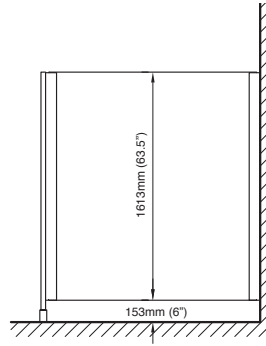

side elevation

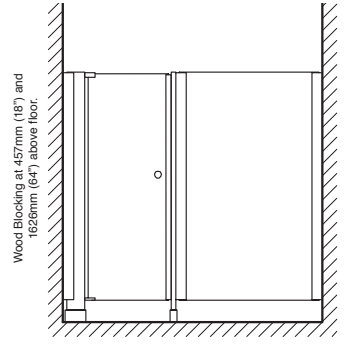

alcove elevation

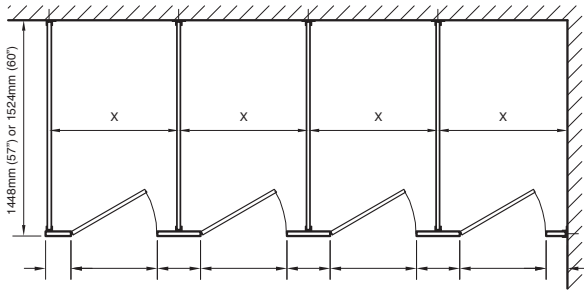

plan

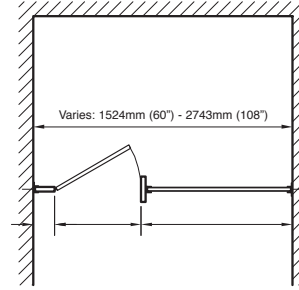

alcove plan

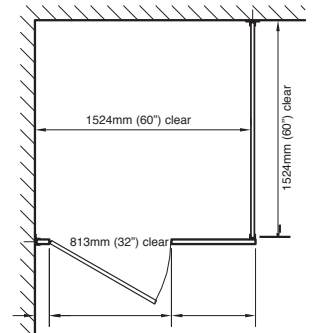

barrier-free plan

Barrier-free units to be mounted
229mm (9 inches) above the floor

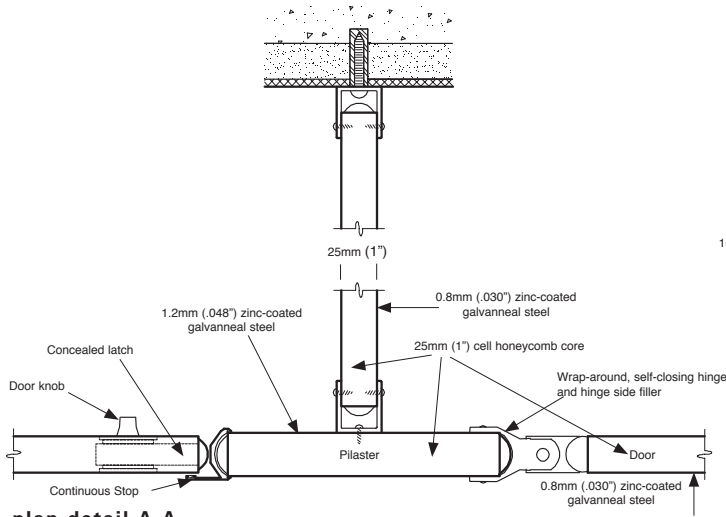

plan detail A-A

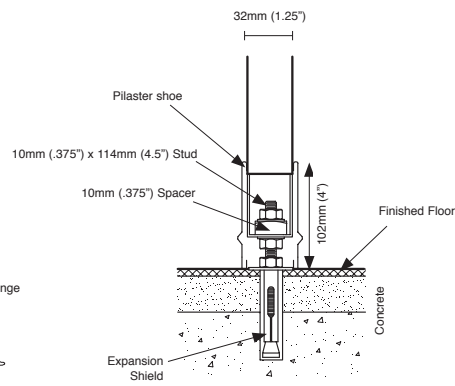

section detail C-C

Important Notes:

Refer to final drawings for wood blocking information. Wood blocking is critical to ensure a rigid installation. For floor conditions other than as shown, obtain special anchoring details.

