

Stainless Steel - Floor to Ceiling ELITE SERIES Metal Toilet Partitions

Material Specification

1 . 0 1 Construction

Doors, Panels and Pilasters shall be constructed of two sheets of panel flatness type 304, #4 brushed finish stainless steel, laminated under pressure to a "Verticel" (1/2") honeycomb core for impact resistance, rigidity and sound deadening. Formed edges to be welded together and interlocked, under tension, with a roll-formed oval crown stainless steel locking bar, mitred, welded and ground smooth at the corners. Honeycomb to be of virgin, long fiber paper with a maximum 12.5mm (1/2") cell size.

1 . 0 2 Doors

Shall be 1613mm (63.5") high and 25mm (1") thick with cover sheets not less than 0.8mm (.030").

1 . 0 3 Panels

Shall be 1613mm (63.5") high and 25mm (1") thick with cover sheets not less than 0.8mm (.030").

1 . 0 4 Pilasters

Shall be 32mm (1.25") thick cover sheets not less than 1.2mm (.048").

1 . 0 5 Pilaster Fastening Method

AT FLOOR: Pilasters shall be securely and rigidly fastened to the floor and fitted with a jack levelling screw for vertical adjustment. The floor fastening shall be concealed and protected by a 102mm (4") high, die-formed stainless steel pilaster shoe.

AT CEILING: Pilasters shall be rigidly fastened to structural steel or pre-cast concrete supporting member (Note: wood support is not acceptable) by means of two heavy hanging studs permitting vertical adjustment between bottom of supporting member and finished ceiling line. Hadrian supplied ceiling studs MUST be used to create a secure installation. The top connection shall be concealed by a 102mm (4") high, die-formed stainless steel pilaster shoe. NOTE: The specification does not include the supplying, installing, drilling or tapping of any of the structural members required in the ceiling for the support of these units. Only the studs are supplied for installation by others.

1 . 0 6 Hardware & Fittings

All panel and pilaster brackets and all door hardware shall be chrome plated zinc die castings, standard. Fasteners are 12 x 1-3/4" and 12 x 5/8" TR-27 6-lobe security screws. Doors shall be equipped with a gravity type hinge mounted on the lower pilaster hinge bracket. Door hinges shall be the wrap around type and adjustable to permit the door to come to rest at any position when not latched. Each door to be fitted with a combined coat hook and bumper and a concealed latch, with face mortised flush with edge strip of door. A full height continuous stop and hinge side filler eliminate all sightline gaps between pilasters and doors. Threaded door top hinge pin shall have a metal core and self lubricating nylon sleeve to ensure smooth, quiet operation. Pilaster shoes shall be a welded one-piece design made from polished stainless steel. Two-piece shoes that can disassemble when kicked are unacceptable.

Stainless Steel Hardware Upcharge Option:

- All pilaster, panel and screen brackets are stamped stainless steel, #4 brushed finish.
- All door wrap around hinge brackets are cast stainless steel, #4 brushed finish.
- All 12 x 1-3/4" & 12 x 5/8" TR-27 6-lobe security screws are stainless steel, #4 brushed finish.
- All pilaster shoes are stainless steel, #4 brushed finish.
- All inner, barrier free inner, outer, door pulls, stop and keepers, coat hooks and door castings are standard zinc die castings, #4 brushed finish.
- All other components not outlined here are standard Hadrian hardware items.

1 . 0 7 Finish

Type 304, #4 brushed finish.

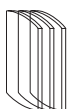



Stainless Steel - Floor to Ceiling ELITE SERIES Metal Toilet Partitions

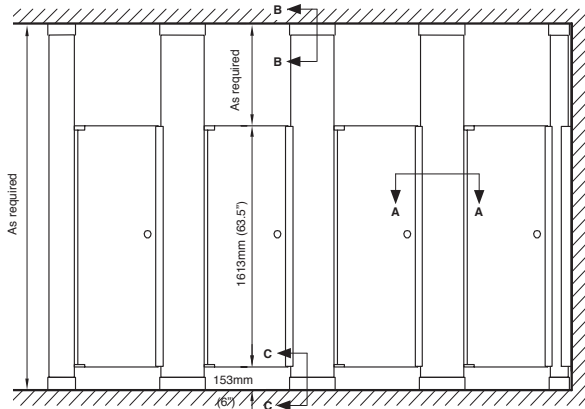

front elevation

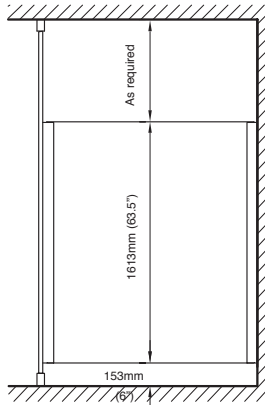

side elevation

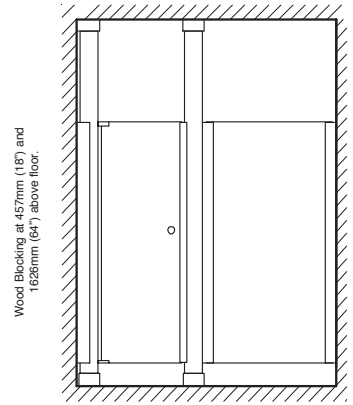

alcove elevation

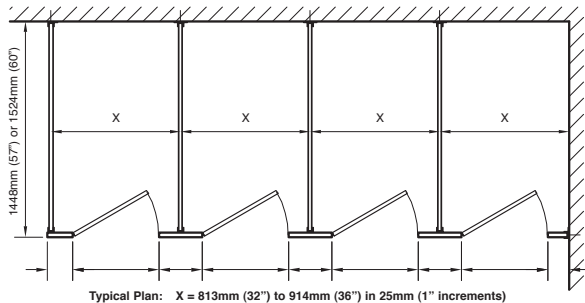

plan

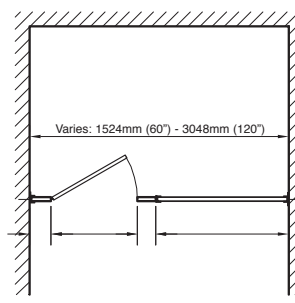

alcove plan

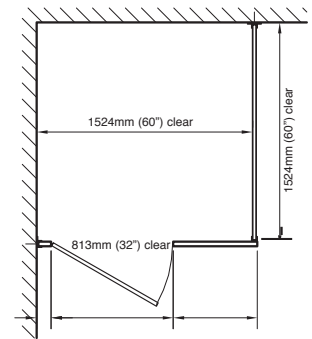

barrier-free plan

Option: Barrier-free units can be mounted 229mm (9") above the floor upon request.

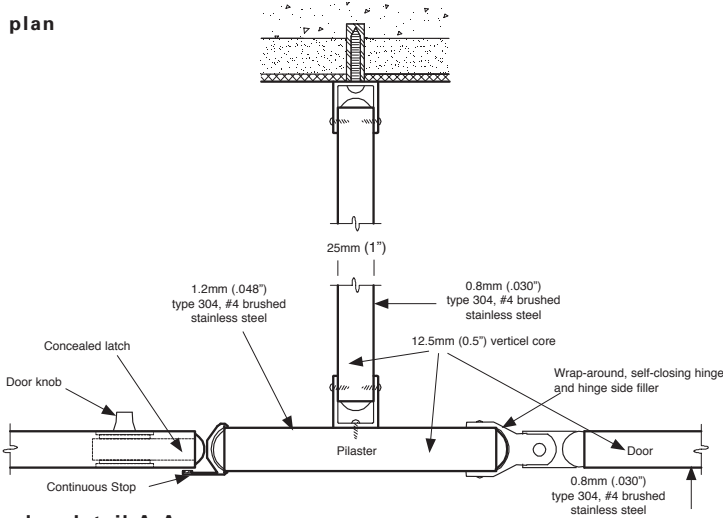

plan detail A-A

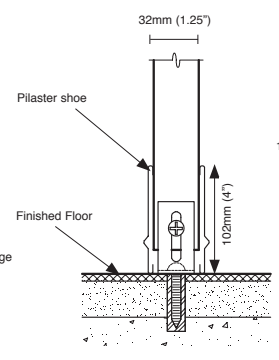

section details C-C

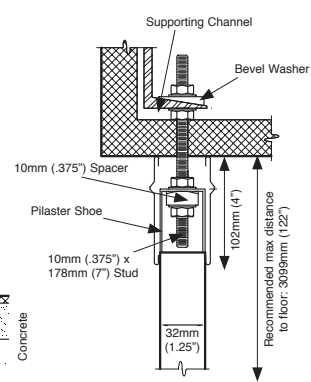

section B-B

Important Notes:
Refer to final drawings for wood blocking information. Wood blocking is critical to ensure a rigid installation. Structural steel or pre-cast concrete required as ceiling support. Wood support is not acceptable. Structural ceiling support and drilling for studs by others. Studs supplied by Hadrian but installed by others. Hadrian supplied ceiling studs MUST be used to create a secure installation.

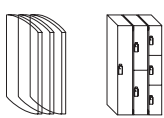

Hadrian Manufacturing Inc., 965 Syscon Road, Burlington, ON, Canada, L7L 5S3 • Tel: (905) 333-0300 • Fax: (905) 333-1841
Hadrian Inc., 7420 Clover Avenue, Mentor, OH, U.S.A., 44060 • Tel: (440) 942-9118 • Fax: (440) 942-9618
www.hadrian-inc.com