

Ceiling Hung STANDARD Solid Plastic Toilet Partitions

Material Specification

1 . 0 1 **Construction**

Doors, panels and pilasters shall be certified CLASS B polyethylene or 100% post-consumer recycled polyethylene solid plastic. The material shall contain no foaming agents, which can cause the formation of air pockets. The self-lubricating surface is resistant to marking and can be maintained effectively with ordinary household cleaners. Material is ideal for toilet partition installations, especially in high abuse and high moisture environments.

1 . 0 2 **Doors**

Shall be (25mm) 1" thick by (1397mm) 55" high straight cut with fine radius edges.

1 . 0 3 **Panels**

Shall be (25mm) 1" thick by (1397mm) 55" high straight cut with fine radius edges.

1 . 0 4 **Pilasters**

Shall be (25mm) 1" thick and straight cut with fine radius edges.

1 . 0 5 **Pilaster Fastening Method**

Pilasters shall be securely and rigidly fastened to structural steel or pre-cast concrete supporting member in ceiling (note: wood support is not acceptable) by means of two heavy hanging studs permitting vertical adjustment between bottom of supporting member and finished ceiling line. Heavy hanging studs to be attached to pilasters by means of a heavy duty, 3/8" (10mm) thick mounting bracket. Hadrian supplied ceiling studs MUST be used to create a secure installation. The ceiling fastening shall be concealed and protected by a 3" (76mm) stainless steel sleeve pilaster shoe. Ceiling hung partitions will be additionally stabilized by means of a 3" (76mm) stabilizer mounted 7' (2134mm) from the finished floor continuous around the interior of the compartment.

Note: This specification does not include the supplying, installing, drilling or tapping of any of the structural members required in the ceiling for support of these units. Only the studs are supplied for installation by others.

1 . 0 6 **Hardware & Fittings**

Doors are installed with 1/8-inch (3 mm) thick extruded clear anodized, 8 inch (203 mm) rounded aluminum hinges, which wrap around both the door and pilaster. Hinges shall be fastened to door and pilaster with tamper-proof 6-lobe security head stainless steel thru-bolts and to the edge of door and pilaster with #10 by 1-inch (25 mm) screw. Top hinges shall have adjustable nylon cams. Strike-keeper and throw latch shall be of extruded clear anodized aluminum. Three heavy-duty aluminum brackets are used at the panel to wall connection and a full-height continuous aluminum channel is used at the panel to pilaster connection. Hadrian's unique designer coat hook & bumper features a solid cast zinc hook and oversized black rubber bumper that functions as both a door stop and bag hook. Fasteners are theft-proof 6-lobe security head stainless steel screws.

1 . 0 7 **Finish**

Doors, panels and pilasters shall be certified CLASS B polyethylene or 100% post-consumer recycled polyethylene with uniform color throughout. Color shall be as selected from Hadrian's color card.

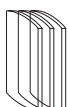

Ceiling Hung STANDARD Solid Plastic Toilet Partitions

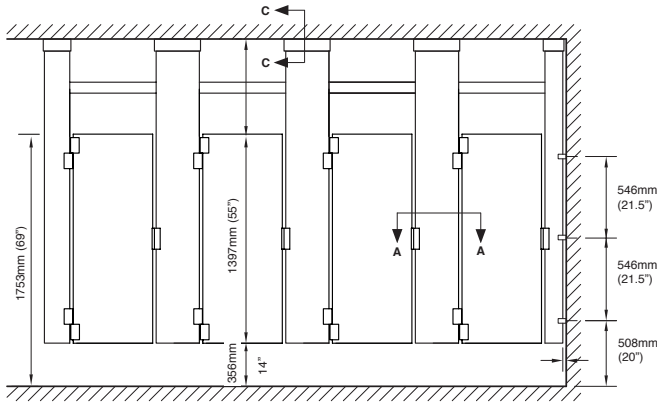

front elevation

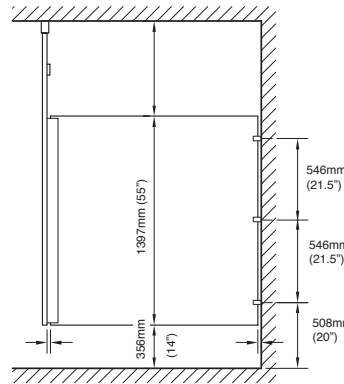

side elevation

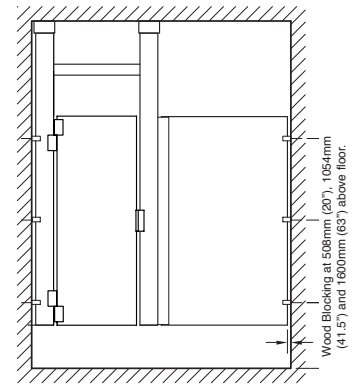

alcove elevation

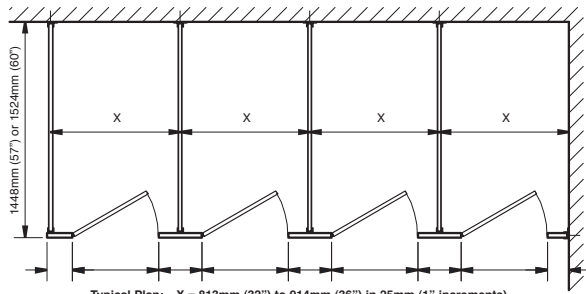

plan

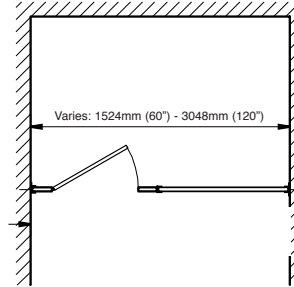

alcove plan

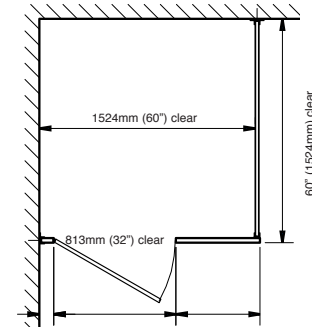

barrier-free plan

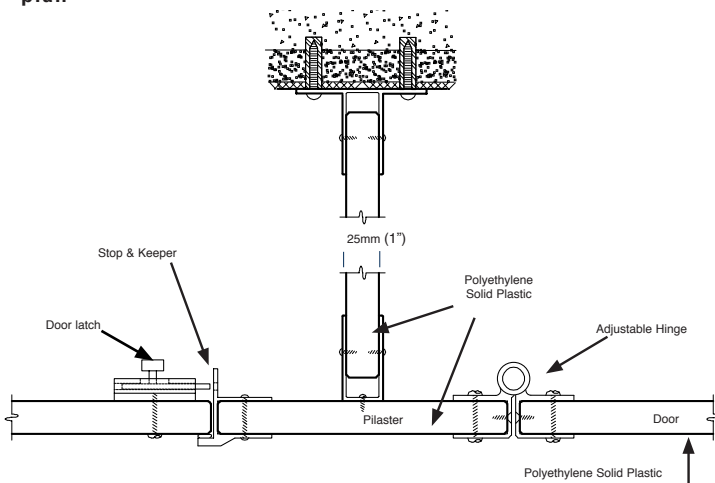

plan detail A-A

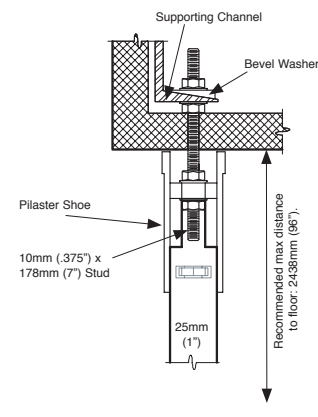

section C-C

Important Notes:

Structural steel or pre-cast concrete required as support in ceiling.
Structural support and drilling for studs by others. Studs available from Hadrian but installed by others.
Refer to final drawings for wood blocking information. Wood blocking is critical to ensure a rigid installation.
Hadrian supplied ceiling studs MUST be used to create a secure installation.

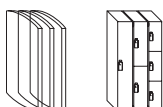

Hadrian Manufacturing Inc., 965 Syscon Road, Burlington, ON, Canada, L7L 5S3 • Tel: (905) 333-0300 • Fax: (905) 333-1841
Hadrian Inc., 7420 Clover Avenue, Mentor, OH, U.S.A., 44060 • Tel: (440) 942-9118 • Fax: (440) 942-9618
www.hadrian-inc.com