

WALL MOUNTED - EMBOSSED STAINLESS STEEL METAL URINAL SCREENS - ELITE PLUS**1.01 Construction**

Screens shall be constructed of two sheets of type 304, Embossed stainless steel with 5WL® pattern, laminated under pressure to a “vertical” honeycomb core for impact resistance, rigidity and sound deadening. Honeycomb to be of virgin, long fiber paper with a maximum 19mm (0.75”) cell size. Formed edges to be welded together and interlocked, under tension, with a roll-formed oval crown stainless steel locking bar, mitred, welded and ground smooth at the corners.

1.02 Wall Mounted

Screens shall be 25mm (1”) thick with cover sheets not less than 22-gauge (0.8mm / .030”). Screens shall be 457mm (18”) or 610mm (24”) deep by 1219mm (48”) high and anchored into the wall approximately 305mm (12”) off the floor.

1.03 Hardware & Fittings

Screens shall be fastened to the wall with double-ear brackets that are stamped stainless steel 304 #4 brushed. Floor mounted with pilaster and floor to ceiling mounted with post to be fastened to the front support with “U” brackets that are stamped stainless steel 304 #4 brushed. Fasteners are theft-proof 6-lobe security head stainless steel screws.

1.04 Finish

Type 304 embossed stainless steel with 5WL® pattern.

FLOOR MOUNTED WITH PILASTER - EMBOSSED STAINLESS STEEL METAL URINAL SCREENS - ELITE PLUS**1.01 Construction**

Screens shall be constructed of two sheets of type 304, Embossed stainless steel with 5WL® pattern, laminated under pressure to a "vertical" honeycomb core for impact resistance, rigidity and sound deadening. Honeycomb to be of virgin, long fiber paper with a maximum 19mm (0.75") cell size. Formed edges to be welded together and interlocked, under tension, with a roll-formed oval crown stainless steel locking bar, mitred, welded and ground smooth at the corners.

1.02 Floor Mounted with Pilaster

Screens shall be 25mm (1") thick with cover sheets not less than 22-gauge (0.8mm / .030"). Screens shall be 1626mm (64") high, in depths ranging from 457mm (18") to 1473mm (58") and anchored into the wall approximately 152mm (6") off the floor.

Floor supporting pilasters shall be 127mm(5") wide by 32mm(1.25") thick with cover sheets not less than 18 - gauge(1.2mm / .048"). Supporting pilasters shall be securely and rigidly fastened to the floor using 19mm(0.75") diameter expansion shields with spacers and nuts for leveling. Floors, preferably concrete, should not be less than 127mm(5") thick for rigidity and anchorage. The floor fastening shall be concealed and protected by a 102mm(4") high, die-formed #4 brushed finish stainless steel pilaster shoe.

1.03 Hardware & Fittings

Screens shall be fastened to the wall with double-ear brackets that are stamped stainless steel 304 #4 brushed. Floor mounted with pilaster and floor to ceiling mounted with post to be fastened to the front support with "U" brackets that are stamped stainless steel 304 #4 brushed. Fasteners are theft-proof 6-lobe security head stainless steel screws.

1.04 Finish

Type 304 embossed stainless steel with 5WL® pattern.

FLOOR TO CEILING WITH POST - EMBOSSED STAINLESS STEEL METAL URINAL SCREENS - ELITE PLUS**1.01 Construction**

Screens shall be constructed of two sheets of type 304, Embossed stainless steel with 5WL® pattern, laminated under pressure to a “vertical” honeycomb core for impact resistance, rigidity and sound deadening. Honeycomb to be of virgin, long fiber paper with a maximum 19mm (0.75”) cell size. Formed edges to be welded together and interlocked, under tension, with a roll-formed oval crown stainless steel locking bar, mitred, welded and ground smooth at the corners.

1.02 Floor to Ceiling with Post

Screens shall be 25mm (1”) thick with cover sheets not less than 22-gauge (0.8mm / .030”). Screens shall be 1829mm (72”) high, in depths ranging from 457mm (18”) to 1499mm (59”) and anchored into the wall approximately 152mm (6”) or 229mm (9”) off the floor.

Floor to ceiling supporting post shall be 44mm(1.75”) square by 3048mm(120”) long and shall be extruded aluminum with a clear anodized finish. Post is to be cut on site to suit floor to ceiling dimension and mounted to floor and ceiling with cast zamac chrome plated post shoes.

1.03 Hardware & Fittings

Screens shall be fastened to the wall with double-ear brackets that are stamped stainless steel 304 #4 brushed. Floor mounted with pilaster and floor to ceiling mounted with post to be fastened to the front support with “U” brackets that are stamped stainless steel 304 #4 brushed. Fasteners are theft-proof 6-lobe security head stainless steel screws.

1.04 Finish

Type 304 embossed stainless steel with 5WL® pattern.

PEDESTAL MOUNTED - EMBOSSED STAINLESS STEEL METAL URINAL SCREENS - ELITE PLUS**1.01 Construction**

Screens shall be constructed of two sheets of type 304, Embossed stainless steel with 5WL® pattern, laminated under pressure to a “vertical” honeycomb core for impact resistance, rigidity and sound deadening. Honeycomb to be of virgin, long fiber paper with a maximum 19mm (0.75”) cell size. Formed edges to be welded together and interlocked, under tension, with a roll-formed oval crown stainless steel locking bar, mitred, welded and ground smooth at the corners.

1.02 Pedestal Mounted

Screens shall be 25mm (1”) thick with cover sheets not less than 22-gauge (0.8mm / .030”). Screens shall be 1829mm (72”) high in depths ranging from 457mm (18”) or 610mm (24”) and anchored into the wall approximately 152mm (6”) or 229mm (9”) off the floor.

Pedestal support shall be 304 #4 brushed stainless steel and to be mounted 152mm (6”) in from the front of the screen.

1.03 Hardware & Fittings

Screens shall be fastened to the wall with double-ear brackets that are stamped stainless steel 304 #4 brushed. Floor mounted with pilaster and floor to ceiling mounted with post to be fastened to the front support with “U” brackets that are stamped stainless steel 304 #4 brushed. Fasteners are theft-proof 6-lobe security head stainless steel screws.

1.04 Finish

Type 304 embossed stainless steel with 5WL® pattern.

Metal Urinal Screens

Elite Plus Series - Wall mounted
 9" [229mm] AFF

Stirrup Bracket Installation

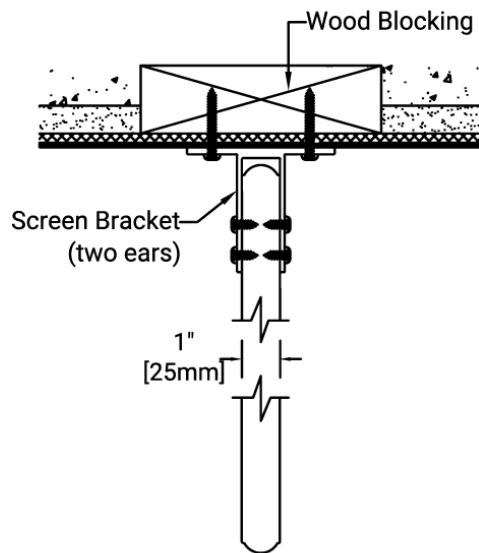
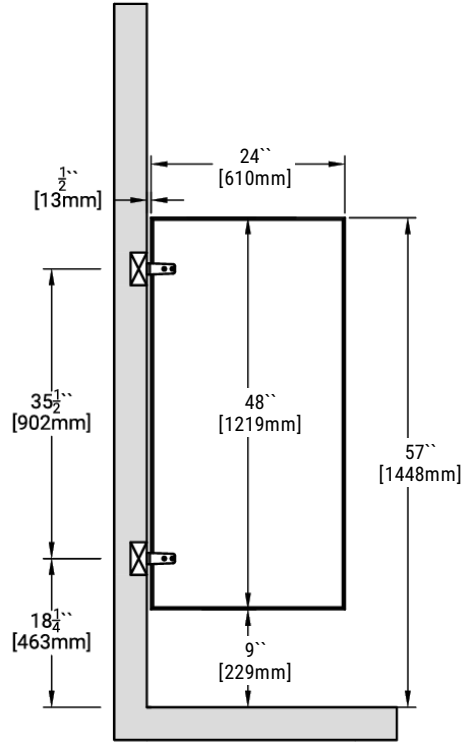

Available Panel Depths
18" [457mm]
24" [610mm]

Metal Urinal Screens

Elite Plus Series - Floor Mounted with Pilaster

6" [152mm] AFF

Stirrup Bracket Installation

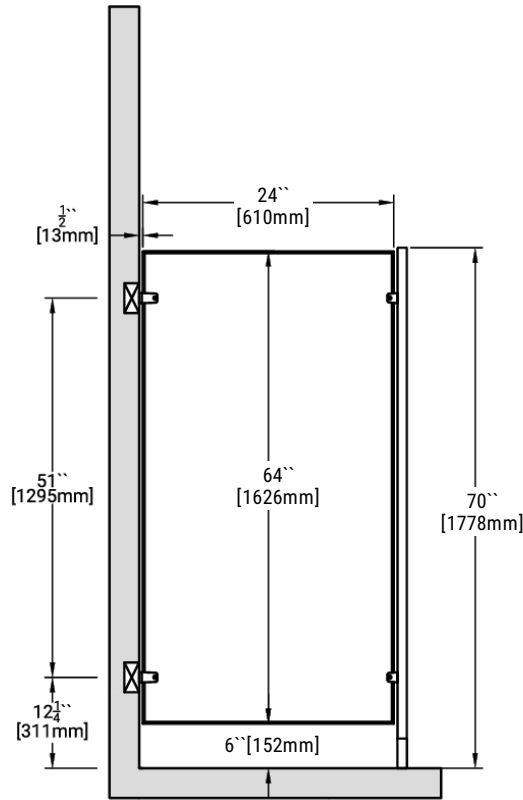

Available Panel Depths

14" [356mm]
18" [457mm]
24" [610mm]
28" [711mm]
34" [864mm]
40" [1016mm]
46" [1168mm]
52" [1321mm]
55" [1397mm]
58" [1473mm]

Note

Floor Mounted with Pilaster option is only available with 64" high panels and is only suitable with 6" AFF.

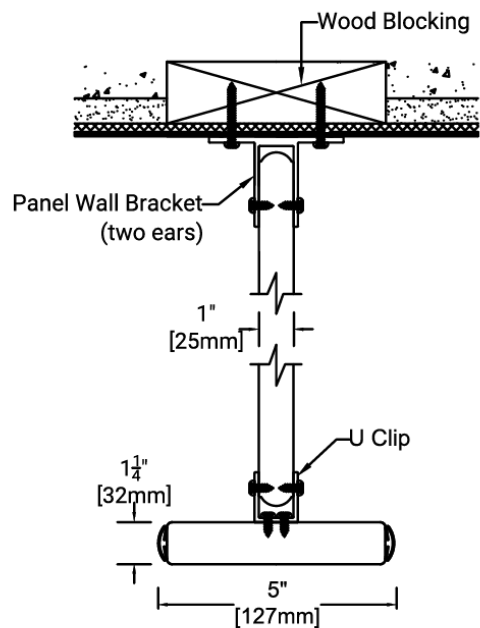

Metal Urinal Screens

Elite Plus Series - Floor to Ceiling Mounted with Post

9" [229mm] AFF

Stirrup Bracket Installation

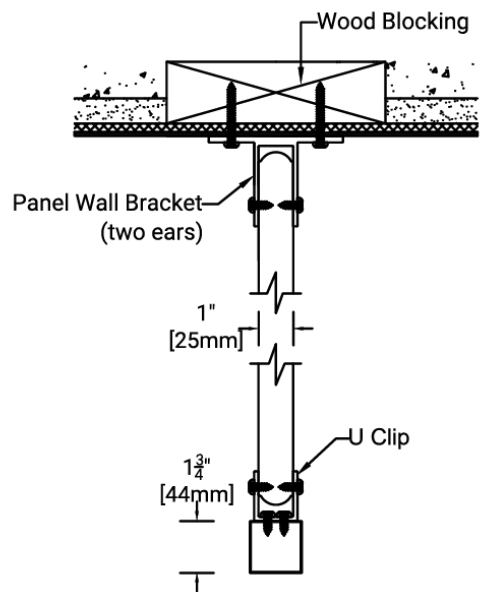
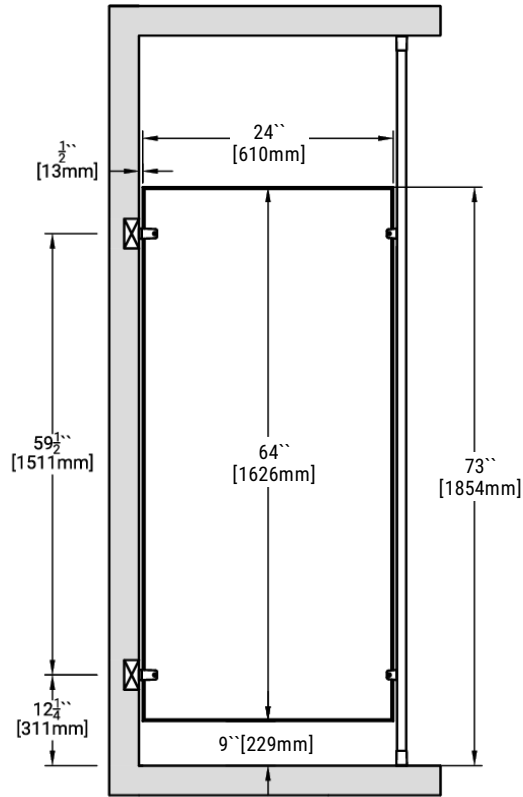

Available Panel Depths

14" [356mm]
18" [457mm]
24" [610mm]
28" [711mm]
34" [864mm]
40" [1016mm]
46" [1168mm]
52" [1321mm]
55" [1397mm]
58" [1473mm]

Metal Urinal Screens

Elite Plus Series - Pedestal mounted
 9" [229mm] AFF

Stirrup Bracket Installation

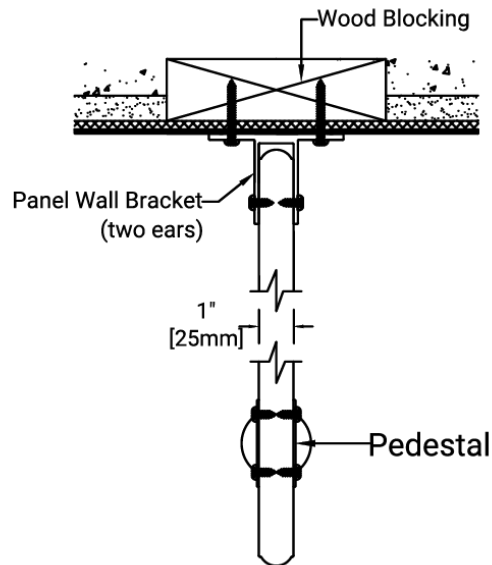
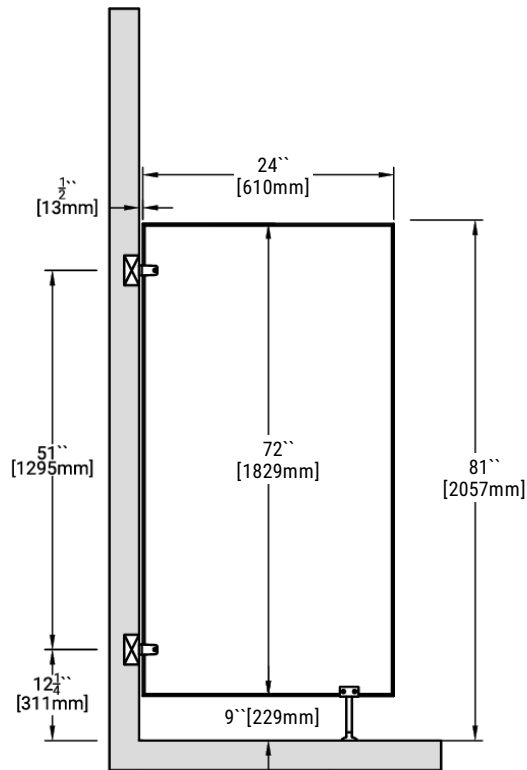

Available Panel Depths

18" [457mm]

24" [610mm]